



**ELCB-82-84**

**EMI/RFI Banding, Self Locking and Shrink Boot Adapter**

**USED ON MIL-DTL--26482 SERIES II & MIL-DTL-5015G**

**ELCB-82-AC-1403-S-SL**

BASIC PART NUMBER \_\_\_\_\_  
 ANGLES (**82**=00°, **83**=45°, **84**=90°) \_\_\_\_\_  
 MATERIAL & FINISH (see table 1) \_\_\_\_\_  
 SHELL SIZE (see table 2) \_\_\_\_\_  
 ENTRY SIZE (see table 3) \_\_\_\_\_  
 BAND (**S** Standard Band, **M** Micro Band) \_\_\_\_\_  
 SELF LOCKING \_\_\_\_\_

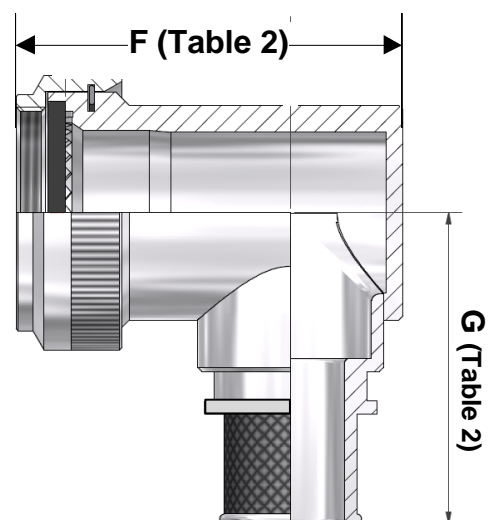
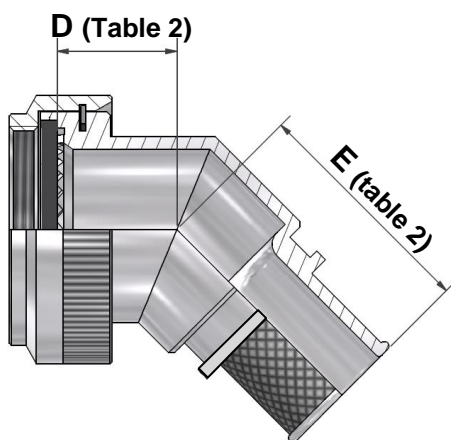
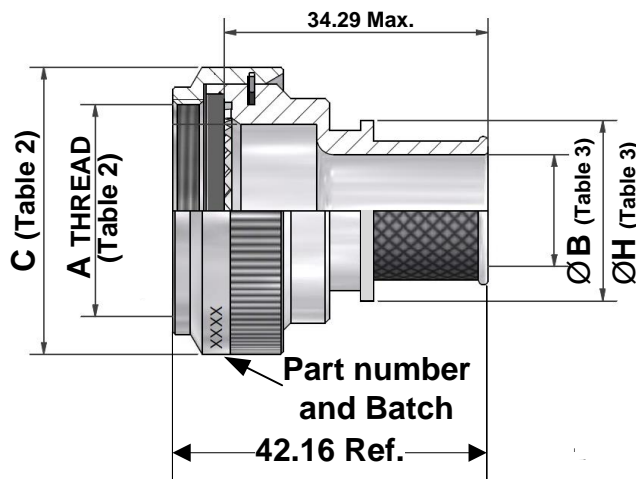



<b>Material: ALUMINUM, FINISH (Table 1)</b>	
AC	CADMIUM OLIVE DRAB OVER, AMS-QQ-P-416 ,Type-II, Class-3. ELECTROLESS NICKEL,AMS-C-26074, Class-4 cgade-B
AE	ELECTROLESS NICKEL AMS-C-26074, Class-4 cgade-B
AZ	ZINC NICKEL ALLOY, DARK OLIVE DRAB PASSIVATE OVER ELECTROLESS NICKEL ASTMS 841-91.

<b>ENTRY SIZE (Table 3)</b>						
Shell Size	Entry Size	Ø B Min.	Ø H Min.	Entry Size	Ø B Min.	Ø H Min.
8, 8S	02	N/A	N/A	03	6.60	14.22
10, 10S, 10SL	02	N/A	N/A	03	8.13	16.00
12, 12S	02	8.13	16.00	03	11.43	19.05
14, 14S	02	11.43	19.05	03	14.48	22.61
16, 16S	02	12.95	20.83	03	16.26	24.13
18	02	16.26	24.13	03	19.30	27.18
20	02	16.26	24.13	03	20.83	28.07
22	02	17.78	25.99	03	24.13	32.00
24	02	19.30	27.18	03	25.65	33.53
28	02	22.6	30.2	03	29.00	37.30

<b>SHELL SIZE (Table 3)</b>						
Shell Size	A Thread	C Max.	D Max.	E Max.	F Max.	G Max.
8 & 8S	1/2-20 UNF	21.5	22.1	29.5	30.2	36.0
10, 10S & 10SL	5/8-24 UNEF	25.7	22.6	30.0	32.5	37.6
12 & 12S	3/4-20 UNEF	28.8	23.4	30.5	35.7	39.2
14 & 14S	7/8-20 UNEF	32.0	23.9	31.0	38.9	40.8
16 7 16S	1-20 UNEF	35.2	24.4	31.8	42.0	42.3
18	1 1/16-18 UNEF	38.4	24.9	32.0	43.7	43.9
20	1 3/16-18 UNEF	41.5	25.4	32.8	46.9	45.5
22	1 5/16-18 UNEF	44.7	26.2	33.4	49.2	47.0
24	1 7/16-18 UNEF	47.9	26.7	34.0	53.2	48.7
28	1 3/4-18 UNS	54.2	27.9	35.0	64.3	51.9

**Notes:**

1. THIS PRODUCT IS DESIGNED TO TERMINAING OVERALL HARNESS SHIELDS. THIS BACKSHELL UTILIZE STANDARD BAND RING FOR 360 DEGREES SHIELD TERMINATION AND LOWEST DC RESISTANCED, USE HEAT SHRINKABLE BOOT.
2. BACKSHELL MATES TO MIL-C-5015 Series 3400, MIL-C-26482 Series 2, MIL-C-81703 Series 3, MIL-C-83723 Series I & III.
3. BACKSHELL TO BE PERMANENTLY MARKED WITH CODE IDENTIFICATION NUMBER AND PART NUMBER. (e.g.12321-ELCB-82-AC-1403-S).
4. ALL DIMENSIONS ARE IN MM.