



**ELCB-8**

**EMI/RFI SHIELD SOCK SHRINK BOOT ADAPTER**

**USED ON MIL-DTL--26482 SERIES II & MIL-DTL-5015G**

**ELCB-8-AC-S-1404**

BASIC PART NUMBER \_\_\_\_\_  
 SERIES (For MIL-DTL-5015G (MS3400)  
 (For MIL-DTL-26482 SER. 2) \_\_\_\_\_  
 MATERIAL (see table 1) \_\_\_\_\_  
 FINISH (see table 2) \_\_\_\_\_  
 ANGLES (S=00°, A=45°, R=90°) \_\_\_\_\_  
 SHELL SIZE (see table 3) \_\_\_\_\_  
 ENTRY SIZE (see table 4) \_\_\_\_\_

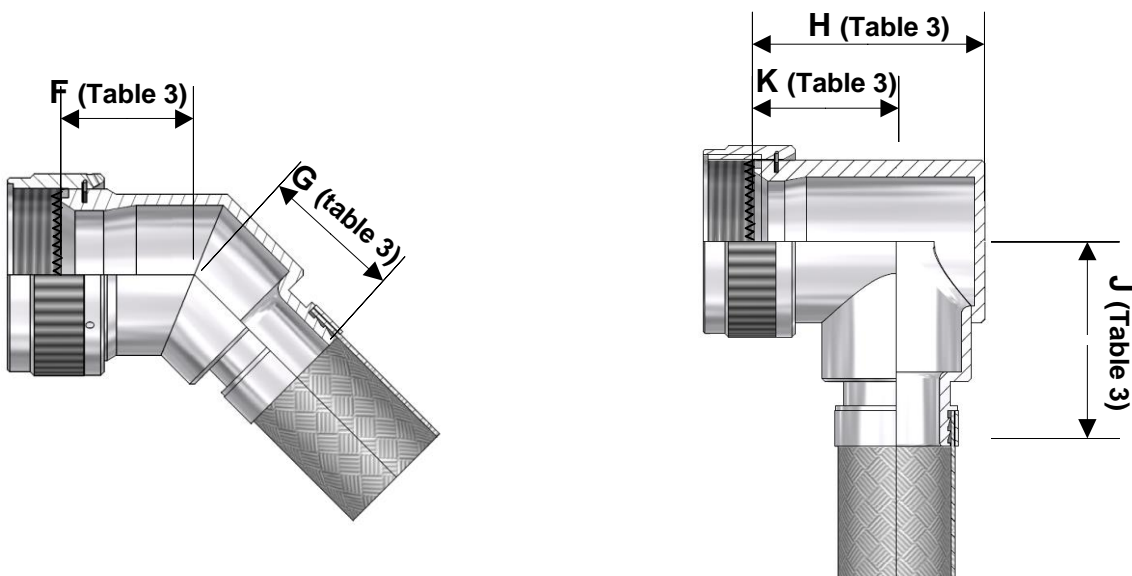
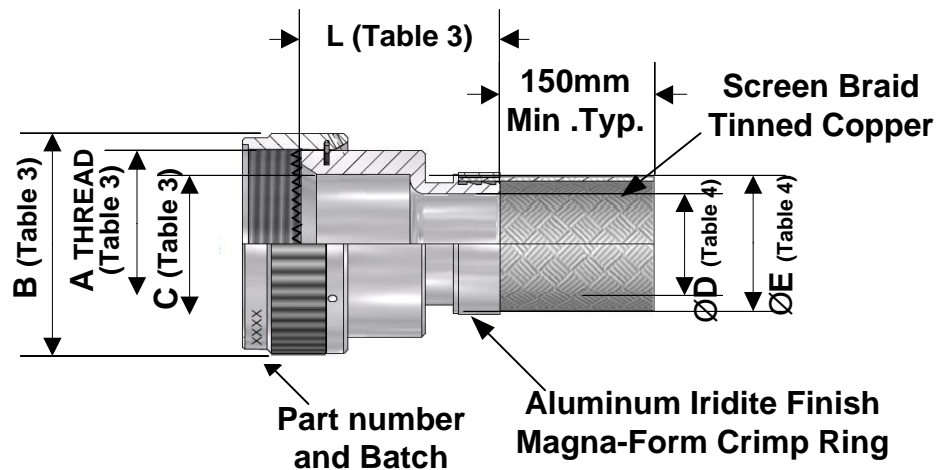



Material (Table 1)	
A	ALUMINIUM
B	NICKEL ALUMINIUM BRONZE
S	STAINLESS STEEL

FINISH (Table 2)	
C	CADMIUM OLIVE DRAB OVER, AMS-QQ-P-416 ,Type-II, Class-3. ELECTROLESS NICKEL, AMS-C-26074, Class-4 cgade-B
B	UNPLATED CLEAN FINISH NOT SHOT BLASTED (FOR NICKEL ALUMINIUM BRONZE)
E	ELECTROLESS NICKEL AMS-C-26074, Class-4 cgade-B
J	PASSIVATE PER QQ-P-35 (FOR STAINLESS STEEL)
Z	ZINC NICKEL ALLOY, DARK OLIVE DRAB PASSIVATE OVER ELECTROLESS NICKEL ASTMS 841-91.
ZB	ZINC NICKEL ALLOY, BLACK PASSIVATE OVER ELECTROLESS NICKEL ASTMS 841-91.

ENTRY SIZE (Table 4)		
Entry Size	Ø D Min.	Ø E Max.
01	6.35	13.10
02	7.92	13.10
03	9.53	17.90
04	12.70	17.90
05	15.88	24.20
06	19.05	24.20
07	22.23	30.60
08	25.40	30.60
09	28.58	37.40
10	31.75	37.40

SHELL SIZE (Table 3)										
Shell Size	A Thread	B Max.	C Min.	F ±0.5	G Max.	H Max.	J Max.	K ±0.5	L ±0.5	Standard Entry size
8 & 8S	1/2-20 UNF	15.6	6.6	16.6	16.9	24.7	23.3	17.5	28.0	01
10, 10S & 10SL	5/8-24 UNEF	18.6	9.3	16.8	17.2	26.7	25.0	17.8	28.0	02
12 & 12S	3/4-20 UNEF	21.7	9.8	17.3	17.6	29.2	26.5	18.7	28.0	03
14 & 14S	7/8-20 UNEF	24.9	14.7	18.1	18.4	30.7	28.1	19.0	28.0	04
16 7 16S	1-20 UNEF	28.2	17.8	19.0	19.2	34.2	29.7	21.0	28.5	05
18	1 1/16-18 UNEF	30.9	19.8	19.2	19.5	37.2	30.4	23.5	28.0	06
20	1 3/16-18 UNEF	34.1	23.0	20.1	20.3	42.2	32.0	27.0	28.0	07
22	1 5/16-18 UNEF	37.3	26.2	20.3	20.8	44.2	33.6	27.0	28.0	08
24	1 7/16-18 UNEF	40.4	29.1	21.8	22.0	46.2	35.1	27.0	28.0	08
28	1 3/4-18 UNS	50.0	34.8	23.3	22.5	54.4	39.9	31.4	36.0	09
32	2-18 UNS	56.3	41.2	25.0	24.2	62.5	43.1	36.4	40.5	09
36	2 1/4-16 UN	62.7	46.6	26.2	25.4	67.4	46.3	38.0	45.0	10
40	2 1/2-16 UN	68.0	52.0	28.6	26.6	73.4	49.3	42.0	50.0	10

**Notes:**

1. THIS PRODUCT IS SUPPLIED WITH LENGTH OF BRAID ATTACHED. THIS BRAID OVERLAPS WITH THE CABLE BRAID AND EFFECTIVE SHIELDING 360 CONTACT, USE HEAT SHRINKABLE BOOT.
2. BACKSHELL TO BE PERMANENTLY MARKED WITH CODE IDENTIFICATION NUMBER AND PART NUMBER. (e.g.12321-ELCB-1-AC-S-1504-S).
3. ALL DIMENSIONS ARE IN MM.