



**ELCB-7**

**EMI/RFI SHIELD SOCK SHRINK BOOT ADAPTER**

**USED ON MIL-DTL-38999 SERIES I & II**

**ELCB-7-AC-S-1404**

BASIC PART NUMBER \_\_\_\_\_  
 SERIES (For MIL-DTL-38999 ser. I&II) \_\_\_\_\_  
 MATERIAL (see table 1) \_\_\_\_\_  
 FINISH (see table 2) \_\_\_\_\_  
 ANGLES (S=00°, A=45°, R=90°) \_\_\_\_\_  
 SHELL SIZE (see table 3) \_\_\_\_\_  
 ENTRY SIZE (see table 4) \_\_\_\_\_

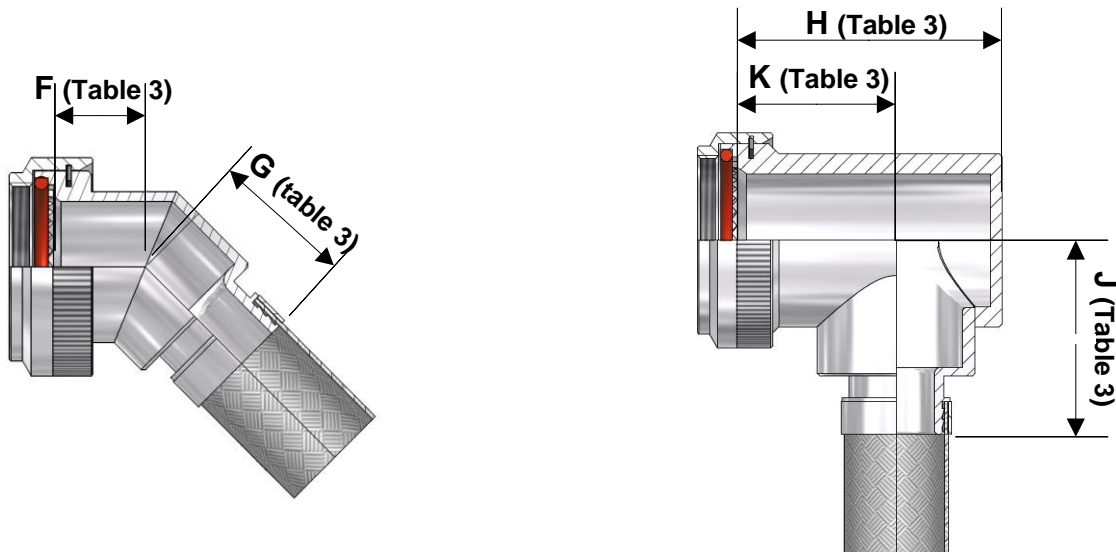
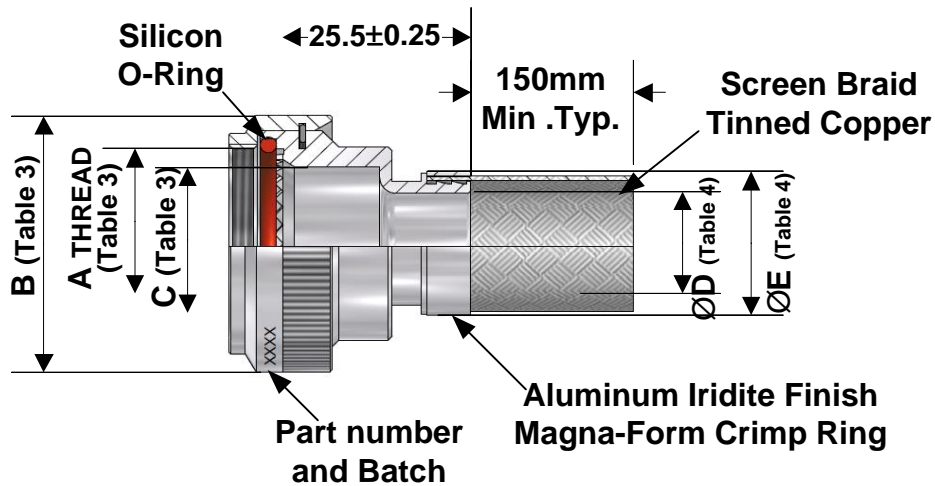



Material (Table 1)	
A	ALUMINIUM
B	NICKEL ALUMINIUM BRONZE
S	STAINLESS STEEL

FINISH (Table 2)	
C	CADMIUM OLIVE DRAB OVER, AMS-QQ-P-416 ,Type-II, Class-3. ELECTROLESS NICKEL, AMS-C-26074, Class-4 cgade-B
B	UNPLATED CLEAN FINISH NOT SHOT BLASTED (FOR NICKEL ALUMINIUM BRONZE)
E	ELECTROLESS NICKEL AMS-C-26074, Class-4 cgade-B
J	PASSIVATE PER QQ-P-35 (FOR STAINLESS STEEL)
Z	ZINC NICKEL ALLOY, DARK OLIVE DRAB PASSIVATE OVER ELECTROLESS NICKEL ASTMS 841-91.
ZB	ZINC NICKEL ALLOY, BLACK PASSIVATE OVER ELECTROLESS NICKEL ASTMS 841-91.

ENTRY SIZE (Table 4)		
Entry Size	Ø D Min.	Ø E Max.
01	6.35	13.10
02	7.92	13.10
03	9.53	17.90
04	12.70	17.90
05	15.88	24.20
06	19.05	24.20
07	22.23	30.60
08	25.40	30.60
09	28.58	37.40
10	31.75	37.40

SHELL SIZE (Table 3)										
Shell Size		A Thread	B Max.	C Min.	F ±0.5	G ±0.5	H Max.	J Max.	K ±0.5	Standard Entry size
Ser.2	Ser.1									
8	09	0.438-28 UNEF	18.0	6.8	16.4	17.1	22.7	24.0	15.0	01
10	11	0.562-24 UNEF	21.0	10.2	17.2	18.2	26.2	25.7	17.0	02
12	13	0.688-24 UNEF	24.5	13.1	17.6	18.6	29.2	27.2	18.0	03
14	15	0.813-20 UNEF	27.8	16.2	18.5	19.5	32.2	28.7	20.0	04
16	17	0.938-20 UNEF	30.8	19.3	19.2	20.3	35.7	30.4	21.5	05
18	19	1.063-18 UNEF	34.1	22.3	19.6	20.8	39.7	32.0	23.0	06
20	21	1.188-18 UNEF	37.3	25.8	20.4	21.7	42.2	33.6	25.0	07
22	23	1.313-18 UNEF	41.0	28.3	20.8	22.0	45.2	35.1	26.0	08
24	25	1.438-18 UNEF	43.7	31.5	21.7	22.9	48.2	36.6	28.0	08

**Notes:**

1. THIS PRODUCT IS DESIGNED TO TERMINATING OVERALL HARNESS SHIELDS. THIS BACKSHELL UTILIZE STANDARD BAND RING FOR 360 DEGREES SHIELD TERMINATION AND LOWEST DC RESISTANCED, USE HEAT SHRINKABLE BOOT.
2. MATED PROVIDE A WATER-TIGHT SEAL MEETING THE REQUIREMENTS OF MIL-C-85049, PAR. 3.5.7.
3. BACKSHELL TO BE PERMANENTLY MARKED WITH CODE IDENTIFICATION NUMBER AND PART NUMBER. (e.g.12321-ELCB-1-AC-S-1504-S).
4. ALL DIMENSIONS ARE IN MM.