



ELCB-1/1

EMI/RFI Banding, Self Locking and Shrink Boot Adapter

USED ON MIL-DTL-38999 SERIES III & IV, only for Straight Adapter

One piece (Style 1) construction

ELCB-1/1-AC-S-1504-2-SL-S

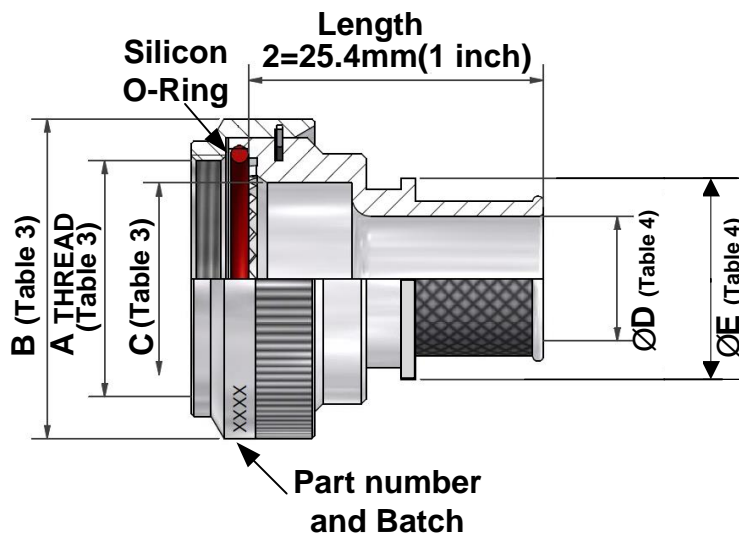
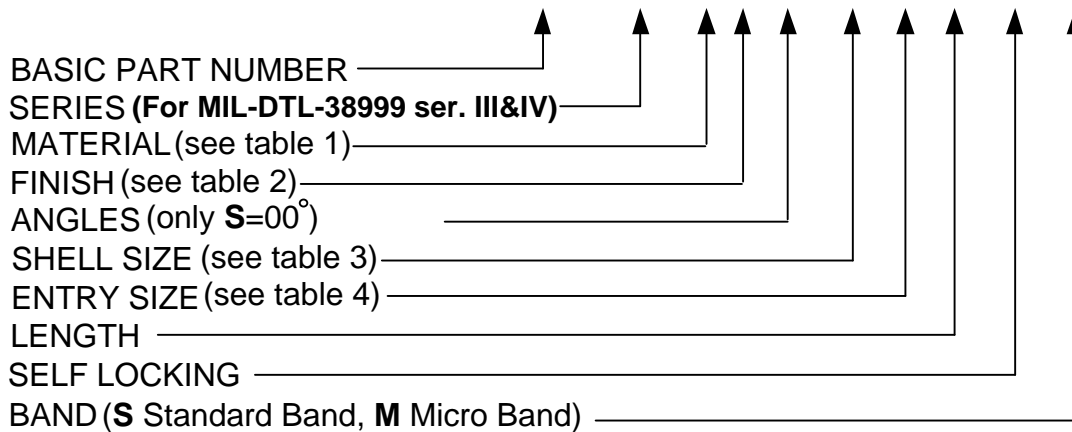



Material (Table 1)	
A	ALUMINIUM
B	NICKEL ALUMINIUM BRONZE
S	STAINLESS STEEL

FINISH (Table 2)	
C	CADMIUM OLIVE DRAB OVER, AMS-QQ-P-416 ,Type-II, Class-3. ELECTROLESS NICKEL, AMS-C-26074, Class-4 cgade-B
B	UNPLATED CLEAN FINISH NOT SHOT BLASTED (FOR NICKEL ALUMINIUM BRONZE)
E	ELECTROLESS NICKEL AMS-C-26074, Class-4 cgade-B
J	PASSIVATE PER QQ-P-35 (FOR STAINLESS STEEL)
Z	ZINC NICKEL ALLOY, DARK OLIVE DRAB PASSIVATE OVER ELECTROLESS NICKEL ASTMS 841-91.
ZB	ZINC NICKEL ALLOY, BLACK PASSIVATE OVER ELECTROLESS NICKEL ASTMS 841-91.

ENTRY SIZE (Table 4)		
Entry Size	Ø D Min.	Ø E Max.
01	6.35	13.90
02	7.92	15.50
03	9.53	17.20
03M	11.10	18.70
04	12.70	20.30
04M	14.27	21.90
05	15.88	23.50
05M	17.47	25.10
06	19.05	26.70
06M	20.52	28.30
07	22.23	29.90
08	25.40	31.50
09	28.58	33.10
10	31.75	34.70

SHELL SIZE (Table 3)					
Shell Size		A	B	C	Standard Entry size
Comercial	Military	Thread	Max.	Min.	
A	09	M12 x 1.0	18.0	6.7	01
B	11	M15 x 1.0	21.0	10.2	02
C	13	M18 x 1.0	24.5	13.5	03
D	15	M22 x 1.0	29.0	16.2	04
E	17	M25 x 1.0	32.5	19.4	05
F	19	M28 x 1.0	35.5	21.8	06
G	21	M31 x 1.0	37.0	25.1	07
H	23	M34 x 1.0	40.0	28.2	08
J	25	M37 x 1.0	43.5	31.4	08

Notes:

1. THIS PRODUCT IS DESIGNED TO TERMINAING OVERALL HARNESS SHIELDS. THIS BACKSHELL UTILIZE STANDARD BAND RING FOR 360 DEGREES SHIELD TERMINATION AND LOWEST DC RESISTANCED, USE HEAT SHRINKABLE BOOT.
2. MATED PROVIDE A WATER-TIGHT SEAL MEETING THE REQUIREMENTS OF MIL-C-85049, PAR. 3.5.7.
3. BACKSHELL TO BE PERMANENTLY MARKED WITH CODE IDENTIFICATION NUMBER AND PART NUMBER. (e.g.12321-ELCB-1-AC-S-1504-S).
4. ALL DIMENSIONS ARE IN MM.